

2x15 CONTROLLED TENSION ANCHORS PER ELEMENT

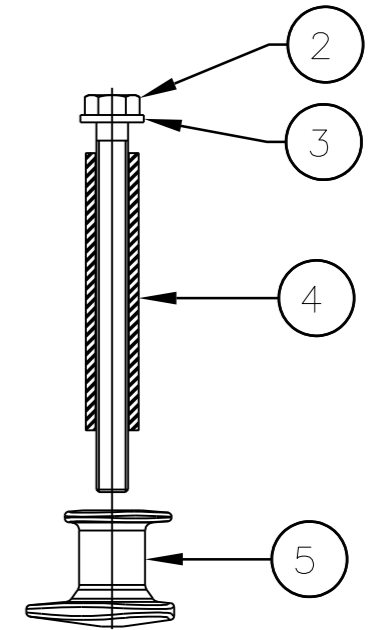

ALUMIUM ELEMENTS

ALUMIUM ELEMENTS

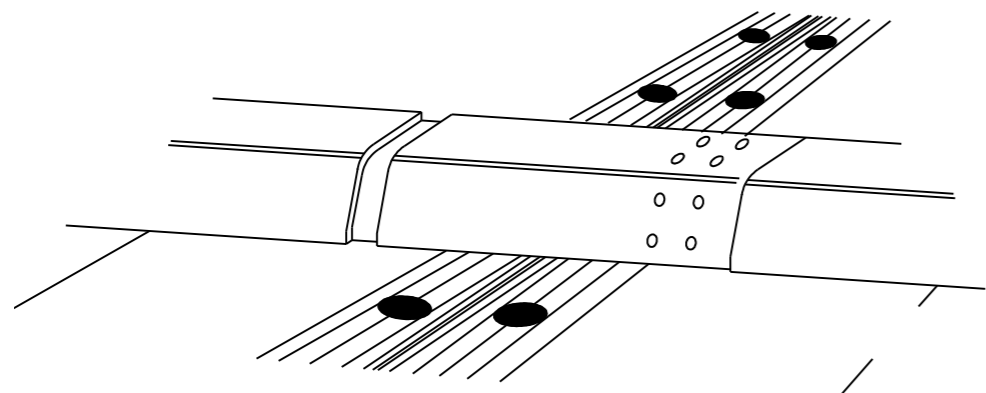
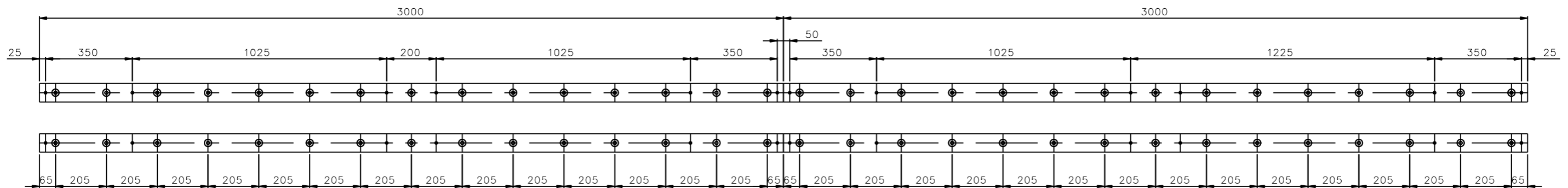

INSTALLATION HANDBOOK
EXPANSION JOINT
N° J-WOSD0-PR-A-001 REV:A

7	Elastomere section
6	Drain Ø20
5	Cast iron socket M12
4	Sheath Ø20 lg. : 105mm
3	Washer Ø24 ep. : 2,8mm
2	Screw H M12 x 140mm
1	Aluminium element
REP	DESIGNATION

INDICE REV.	DATE	DESSINE DRAWN	VERIFIE CHECKED	APPROUVE APPROVED	MODIFICATIONS
A	29/11/12	M.NU	O.BT	P.SN	PREMIERE DIFFUSION / FIRST ISSUE
MATERIE MATERIAL		TRAITEMENT TREATMENT		MASSE / MASS (kg)	

AFFAIRE PROJECT	...			NUMERO NUMBER
DOSSIER FILE	EXPANSION JOINT TYPE			NUMERO NUMBER
DESIGNATION DESIGNATION	WOSD 100 TYPICAL CROSS VIEW			NUMERO NUMBER
FREYSSINET INTERNATIONAL & COMPAGNIE 1 Bis RUE DU PETIT CLAMART TEL : (33.1) 46 01 84 84 78140 VELYZ CEDEX FAX : (33.1) 46 01 85 85 (FRANCE)				FORMAT/SIZE A1
REPRODUCTION ET MODIFICATION INTERDITES COPYRIGHT & MODIFICATION RESERVED				ECHELLE/SCALE 1/1
J18938				A