

SCALE 1:2  
METALLIC ELEMENTS

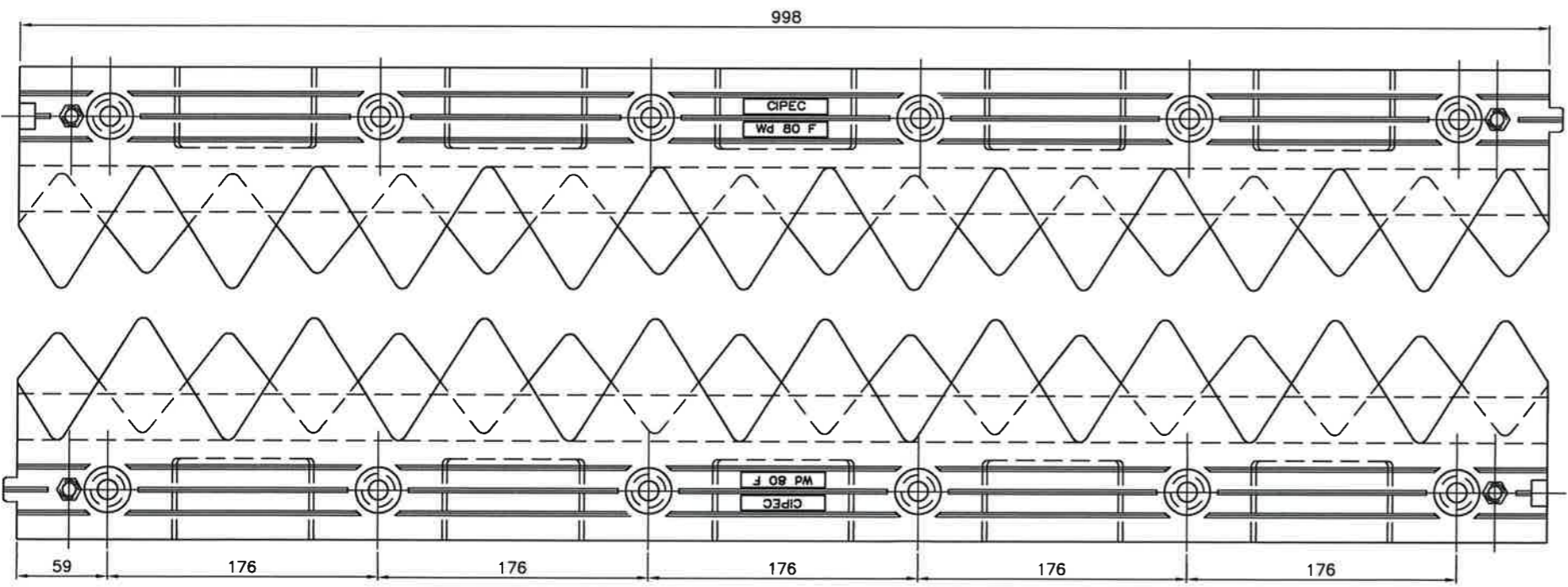

METALLIC ELEMENTS

2x6 CONTROLLED TENSION ANCHORS PER ELEMENT

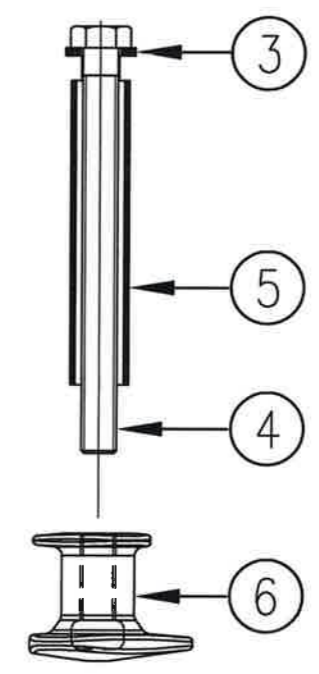

INSTALLATION HANDBOOK  
EXPANSION JOINT  
N° J-WD000-PR-A-001

7	DRAIN $\phi 20$
6	CAST IRON SOCKET M12
5	SHEATH $\phi 20$ TH.=1,6mm LG.=105mm
4	SCREW H M12 LG.=140mm
3	WASHER M12 $\phi 24$ TH.=2,8mm
2	ELASTOMERIC PROFILE WD 80
1	METALLIC ELEMENT WD 80
REP	DESIGNATION

FOR EXECUTION  
-FEX-

INDEX	REV.	DATE	DESIGN	DRAWN	VERIFIE	CHECKED	APPROVE	APPROVED	MODIFICATIONS
A		15.07.15	LMG/AMD	AMT	PSH				PREMIERE DIFFUSION / FIRST ISSUE
MATERIE MATERIAL									
TRAITEMENT TREATMENT									
MASSE / MASS (kg)									

AFFAIRE PROJECT	EXPANSION JOINT	NUMERO NUMBER	R00-902A1
DOSSIER FILE	Wd	NUMERO NUMBER	
DESIGNATION DESIGNATION	Wd 80 TYPICAL CROSS VIEW	FORMAT/SIZE	A1
ECHELLE/SCALE		REVISION	
REVISION		STATUT/STATUS	
FREYSSINET INTERNATIONAL & COMPAGNE 300 RUE HENRI LAFITTE 92000 NANTERRE FRANCE TEL : (33) 1 47 78 78 78 BOITE MAIL: MAIL@FREYSSINET.FR FAX : (33) 1 47 78 78 83		J19309 A FEX	